

## **evolutionDrive HST**

The convenient lift and slide door solution  
for connecting to the great outdoors



# Sliding elements: Unbeatable design, light & comfort

Modern architecture has embraced large-sized sliding doors:

- Sliding elements result in spacious and bright rooms.
- Demands in terms of realisable element sizes are increasing.
- Even in smaller interiors, sliding solutions offer a space-saving outward connection.
- The right elements can also reduce the risk of burglary by 80 %.
- And even in urban regions, noise pollution can be reduced by up to 75 % with the right elements.



# evolutionDrive HST – can be operated with just a single movement

## **Incredibly easy operation**

- Convenient and simple operation with just a single movement
- Smooth sliding and reliable running
- No tripping hazards: Barrier-free design of the threshold – straight and particularly easy to clean
- No slamming of doors with intermittent and full ventilation
- Low-maintenance sliding system

## **Reliable protection**

- Premium gaskets provide optimal protection against wind, hail and pelting rain
- Effective thermal protection
- Security components can be individually adapted to the desired burglar protection level

## **Space miracle**

- Creates generously sized through-ways with a high proportion of glass
- Maximum stability even with wide window fronts
- No space required for opening
- No door sashes projecting into the room
- The high percentage of glass means the living space is flooded with light



# The Salamander C3 principle: The route to the optimum configuration

Thanks to our specially developed processes, you are guaranteed to find the element that meets your specific demands. These three dimensions are central in determining whether your choice suits the building and external influences:

## Climate



### Climate conditions and local factors

Temperature curve and difference, rainfall, hours of sunshine, snowfall, wind loads, burglary rates, air pollution, noise pollution, metres above sea level.

## Case



### Building properties

Year in which the building was constructed, building type, living space, storeys, window frame material, glazing, alignment of the building as per GPS coordinates, number of windows per façade, window types, number of cross bars, window dimensions, analysis of light situation: Comparison of actual and desired light situation.

## Customer



### Customer demands

Strategies to optimise light and energy input, historical authenticity, regional style, individual selection of the design and materiality, ecological factors such as insulation and recycling as well as costs.

## Climate

Thanks to the optimised gasket levels, the evolutionDrive lift and slide door offers efficient thermal protection. As such, heat loss and the risk of condensation are

minimised. With a heat transfer coefficient of up to  $1.3 \text{ W}/(\text{m}^2\text{K})$ , evolutionDrive HST is particularly well suited to sites where a high light input is required.

---

## Case

### Architectural style / window type

Design-oriented style element for new and older buildings.

### Light

The high percentage of glass makes evolutionDrive HST the ideal solution for interior situations where lots of natural light is required.

### Structural analysis

The clever design forms the basis for optimal stability and enables a large percentage of glass thanks to a statically balanced construction. As such, sizes of up to  $6.50 \text{ m} \times 2.70 \text{ m}$  can be realised.

### Alignment

Given the optimised thermal insulation values and high light input, evolutionDrive HST is able to improve the energy balance even on north-facing façades.

---

## Customer

### Sound insulation

Sound protection of up to 43 dB can be achieved with glazing thicknesses of up to 52 mm.

### Burglar protection

With evolutionDrive HST, burglar protection of up to RC2 can be achieved using standard measures.

### Surfaces

Salamander White, White, base material alternatively brown, more than 40 standard film decors as well as customised aluminium cover profiles.

# The most important values at a glance

- The lift and slide system for an open room ambience
- Barrier-free threshold
- Impressive structural analysis with maximum element sizes

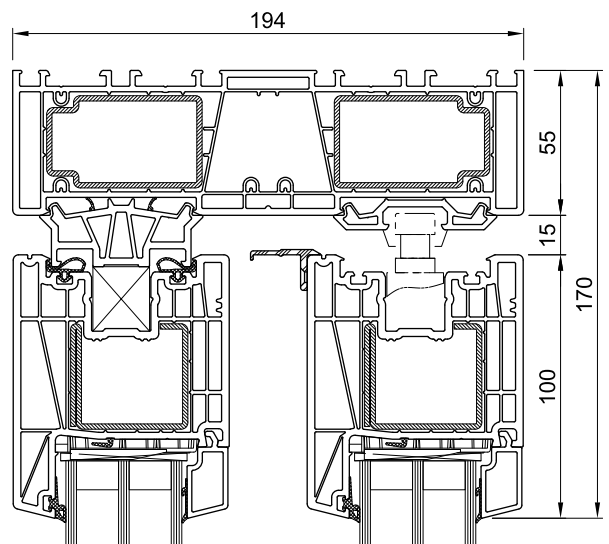

Illustrations not true to size.

<b>Thermal insulation</b>	$U_w$ up to 0.64 W/(m <sup>2</sup> K) $U_f$ up to 1.3 W/(m <sup>2</sup> K)
<b>Sound insulation</b>	up to 43 dB
<b>Safety</b>	RC2
<b>Sash construction depth</b>	82 mm
<b>Frame construction depth</b>	194 mm
<b>Sash view height</b>	100 mm
<b>Frame view height</b>	55 mm
<b>Maximum sizes (with standard sash)</b>	Width up to max. 6,500 mm Height up to max. 2,700 mm
<b>Opening patterns</b>	<p>Pattern A</p> <p>Pattern C</p> <p>Pattern D</p> <p>Pattern G1</p> <p>Pattern K</p>
<b>Application areas</b>	Lift and slide door

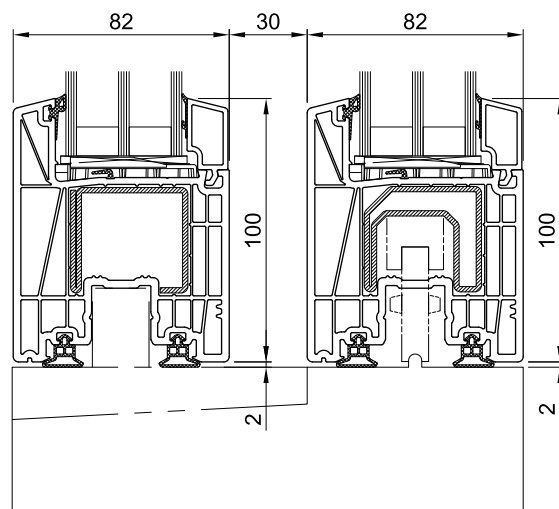

The heat transfer coefficient  $U$ :  
The lower the  $U$ -Value, the less the heat loss in winter and the permeability of heat in summer.  $U_f$  (frame) refers to the insulation value of the frame-sash combination while  $U_w$  (window) refers to the overall structure including the glazing.

# The ideal, more sustainable material – PVC

We specialise in the production of sliding element profiles using the sustainable and long-lasting material PVC and combine this with our innovative surfaces. This enables you to create customised solutions which not only suit the style of the building, but also bring it to life – on the outside and inside.

Today, production at the Salamander Window & Door Systems sites in Türkheim and Włocławek (Poland) is completely powered by green electricity.

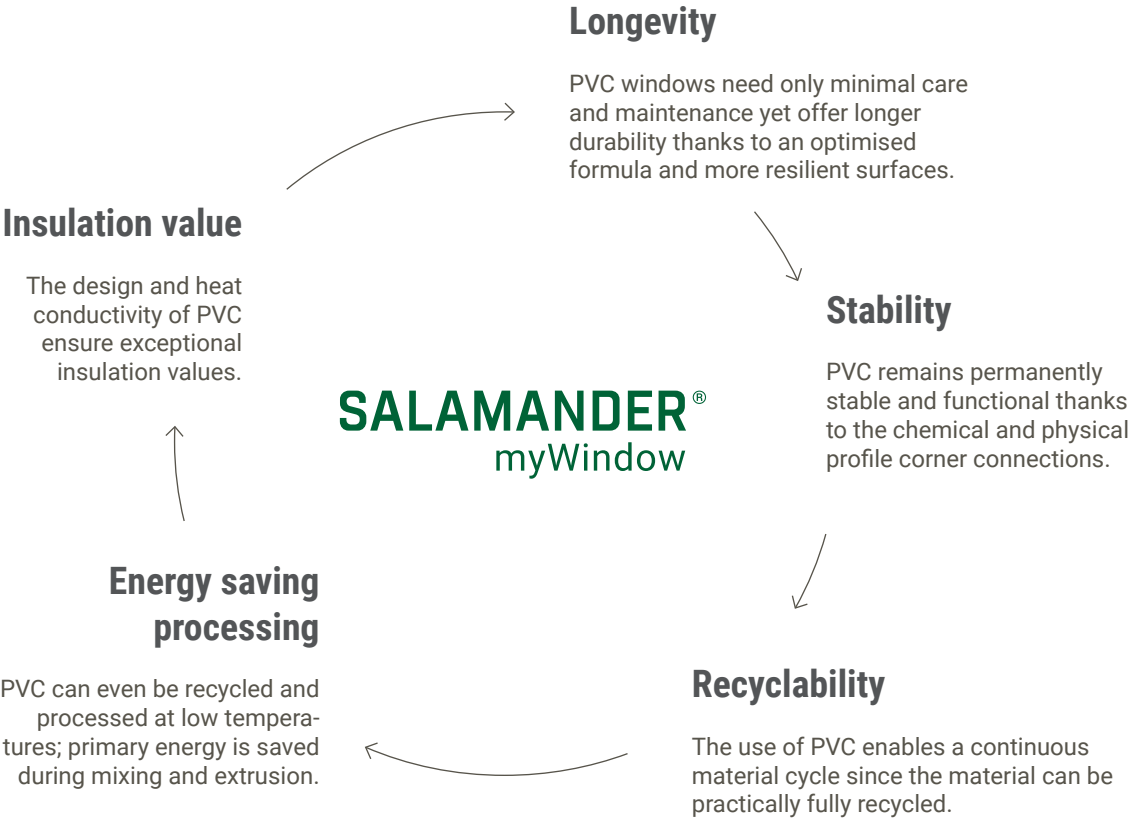

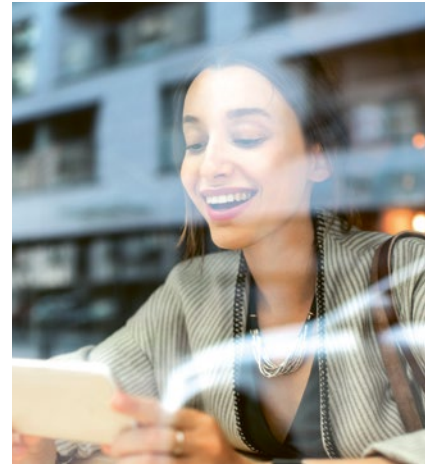

**We have the perfect doors and window to suit your needs –**

thanks to our decades of experience in profile development and PVC extrusion. Long-lasting, customisable and sustainable from the word go: We are continuously developing our systems to offer you the perfect window for the future, today.

**Salamander Industrie-Produkte GmbH**

Jakob-Sigle-Straße 58  
86842 Türkheim  
Germany

[salamander-windows.com](http://salamander-windows.com)



2021-07

